

Bend the Limit

Team

Jimmy Saldivar

Brandon Blue

Garrett Mullen

Randy Quintero



Table of Contents

- **Introduction and Mission Identity (4 minutes)**
 - **Strategic Alignment**
 - **Innovation**
- **Systems and Concept Operations**
- **Engineering Design and Analysis**
 - **CAD**
 - **Bill of Materials**
- **Design Development**
 - **Trade Studies**
 - **Risk Mitigations**
- **Prototype**
- **Lessons Learned and Conclusion**
 - **Challenges**
 - **Closing Statement**

Team Introduction



Randy Quintero Alvarado

Role: Project Lead

*Body Structure, Produced Structures,
Fastening*

Mechanical Engineering Student

Email: rquint41@calstatela.edu



Brandon Blue

Role: Manufacturing & Integration

Material Selection, Prototyping

Engineering Technology Student

Email: bblue@calstatela.edu



Garrett Mullen

Role: Design & Integration

Straightening, Feed, Fastening

Mechanical Engineering Student

Email: gmullen@calstatela.edu



Saldivar, Jimmy

Role: Analysis & Design

*Thermal, Bending Design, Cutting,
Fastening*

Mechanical Engineering Student

Email: jsaidi22@calstatela.edu

Mission Identity

- **Distinct Operations:**
 - **Wire Feed**
 - **Straightening**
 - **Bending**
 - **Cutting**
 - **Fastening**
- **Capability:**
 - **On-Orbit Structural Fabrication**
 - **Antenna Component Manufacturing**
 - **Harness and Routing Support**

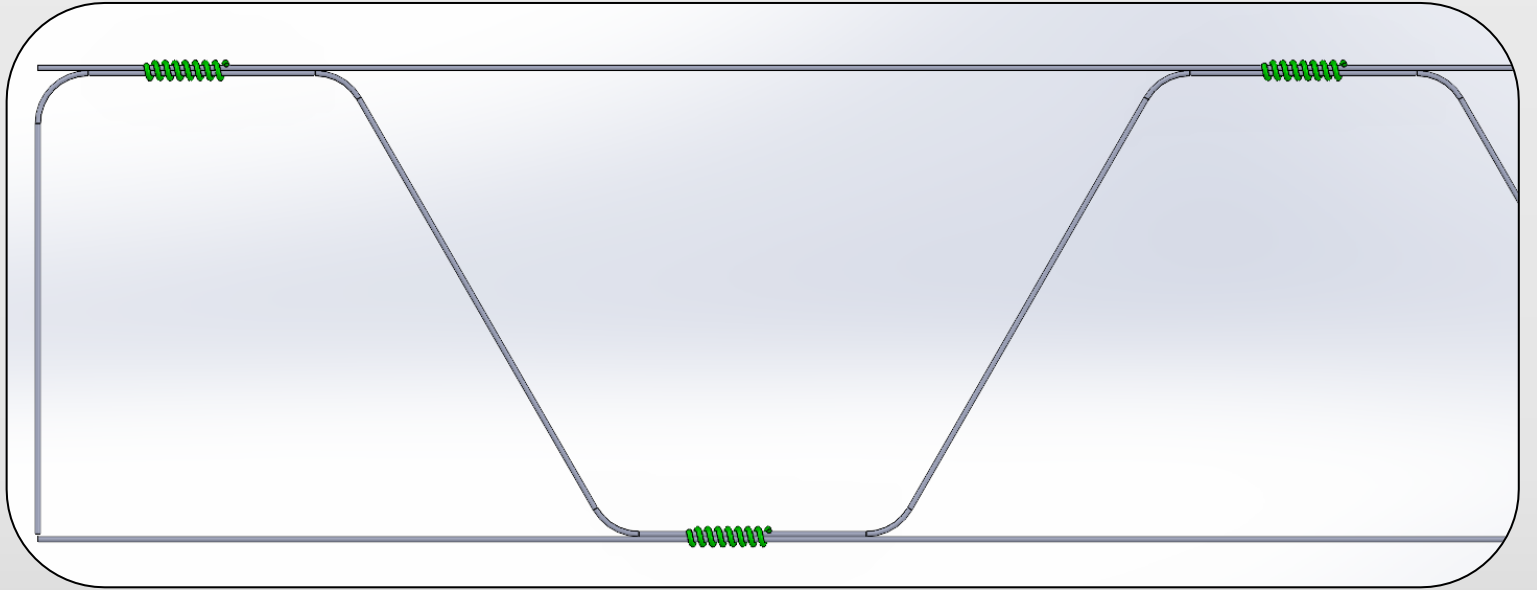

Mission Identity

- Convert spooled wire into structural forms: trusses, triangles, rectangles, and even springs

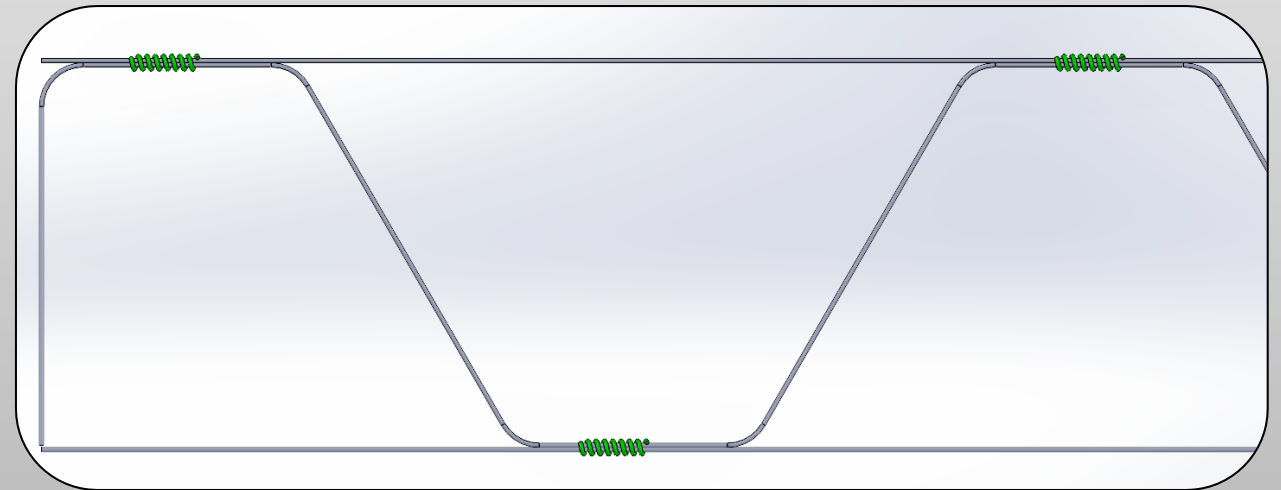
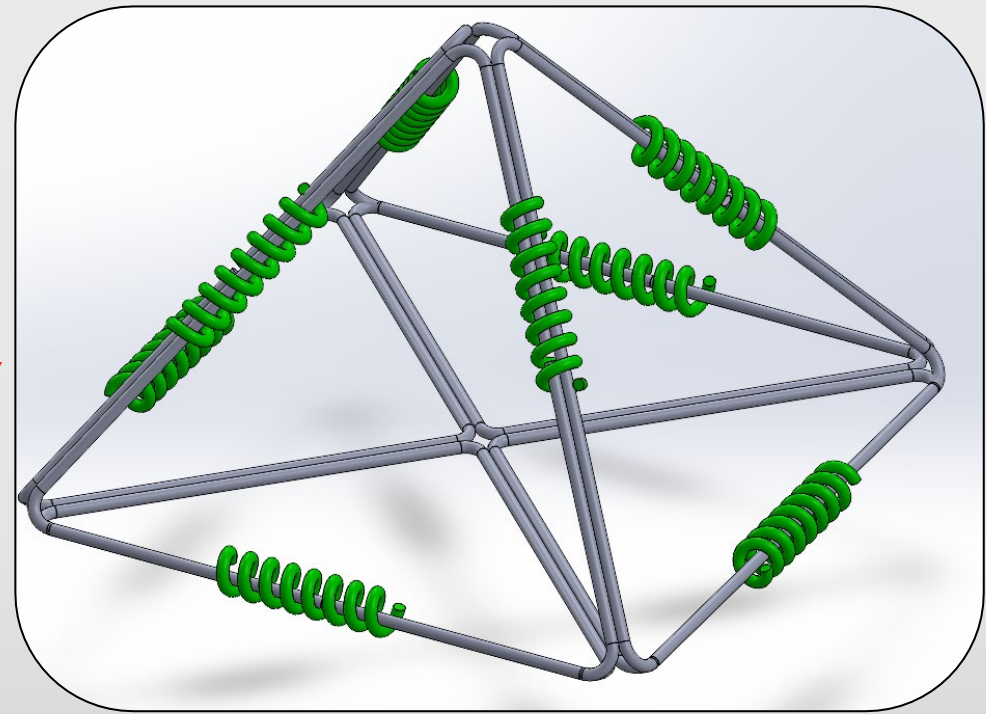
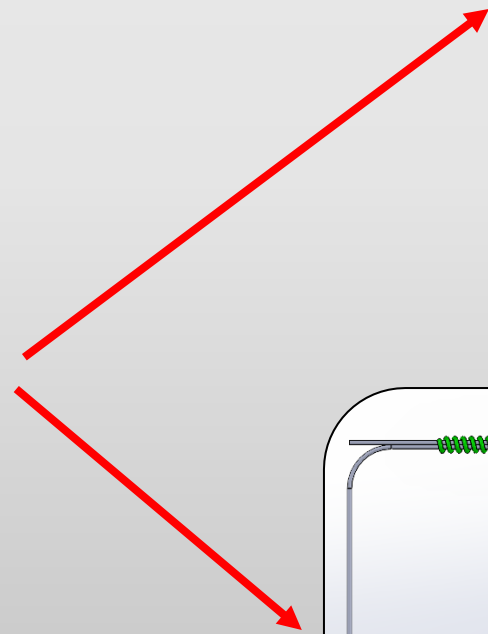

Mission Identity

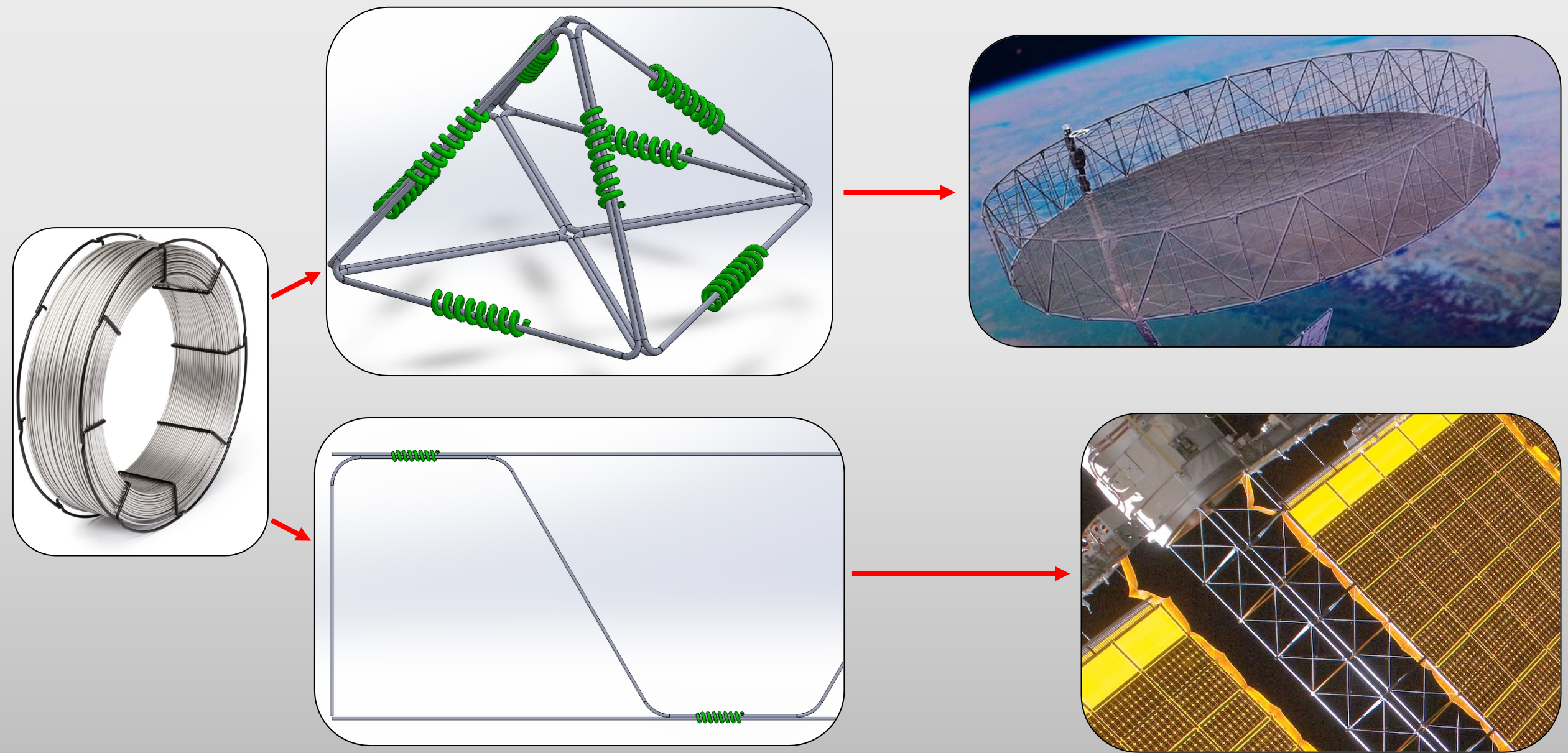

Systems and Concept Operations: Mission Storyboard

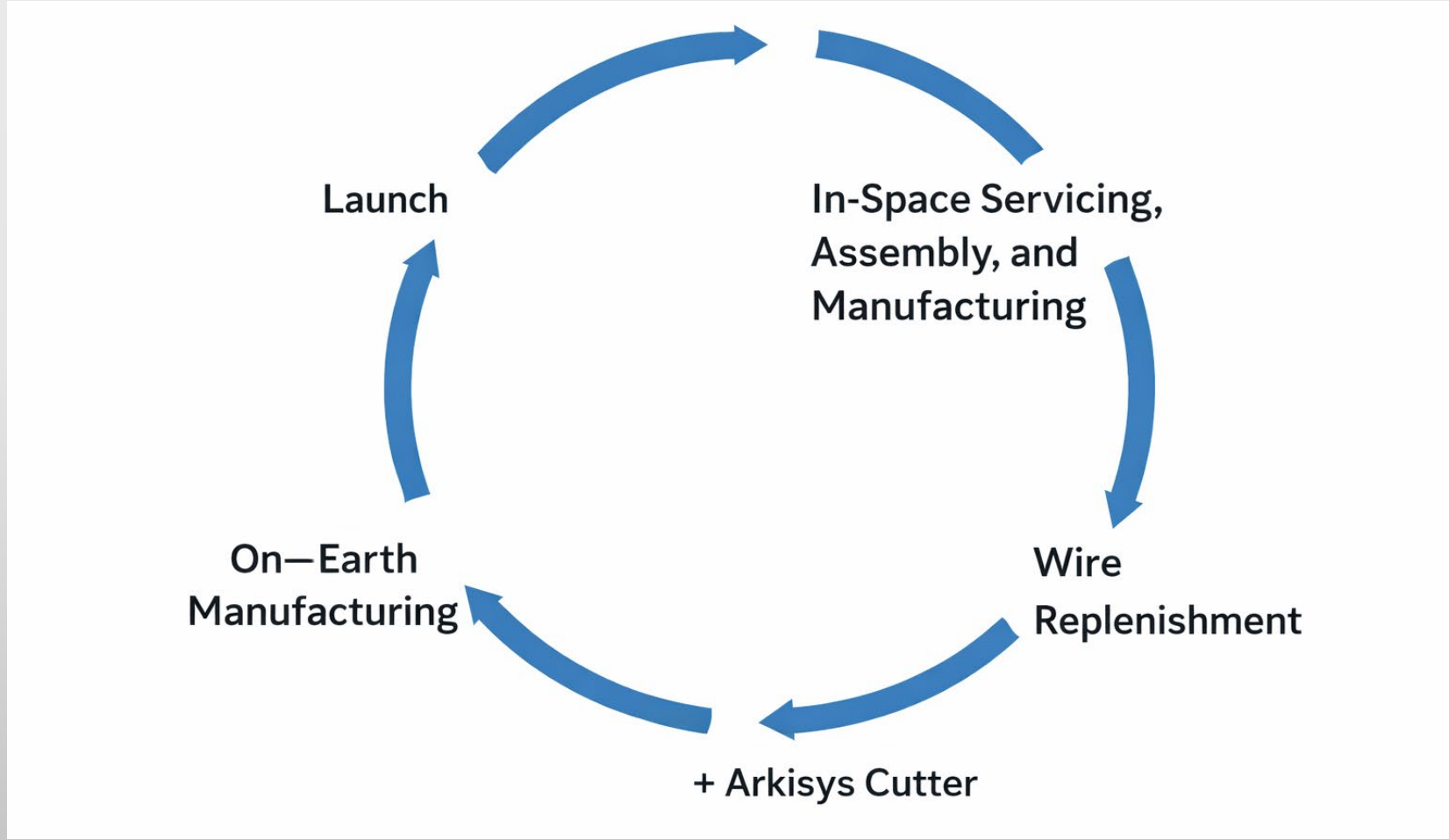

Strategic Alignment

Operational Requirements

- Fit with Bosun's Locker Constraints
(volume, mass, power)
- Autonomous Operation in Microgravity
- Perform at least three discrete operations
(feed → straighten → bend → cut → fasten)



System Architecture

- Spool + Feed system → material delivery
- Straighten + Bending → module formation
- Cutter + Fasten → module completion

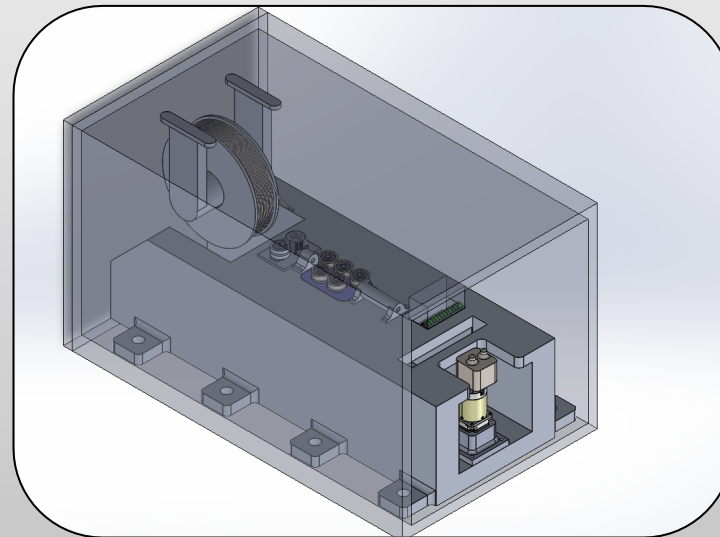

System Outcome

- On-demand in-space manufacturing
- Enables large-scale structures in low Earth orbit
- Reduces launch mass & reliance on Earth
manufacturing



Innovation

- Fastening
- Hinges
- Can accommodate varying diameters

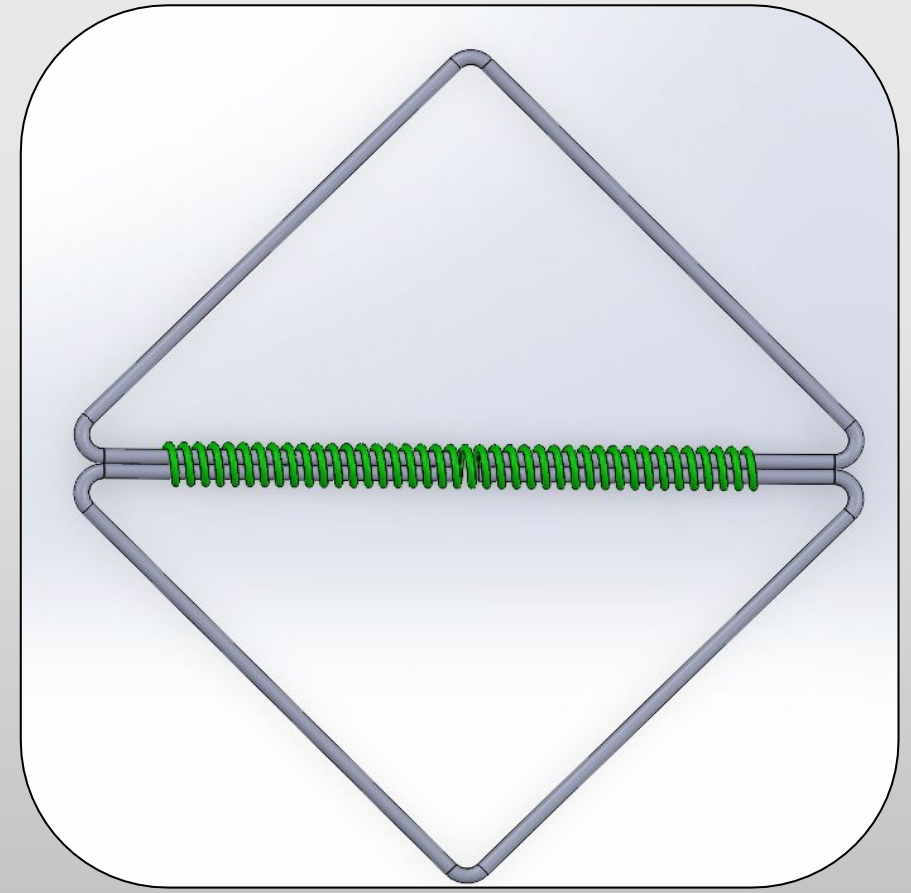
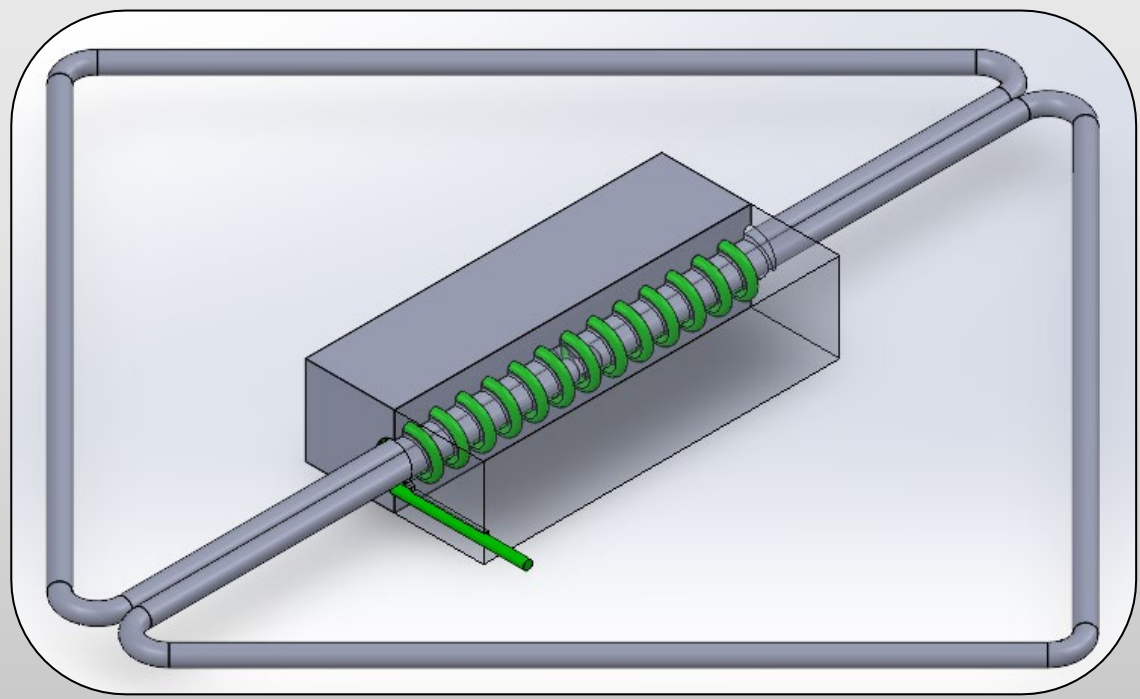

Systems and Concept Operation: Feeding

- Feeding mechanism is driven by a NEMA 17 stepper motor
- An idler roller is used to support the wire during the feeding process

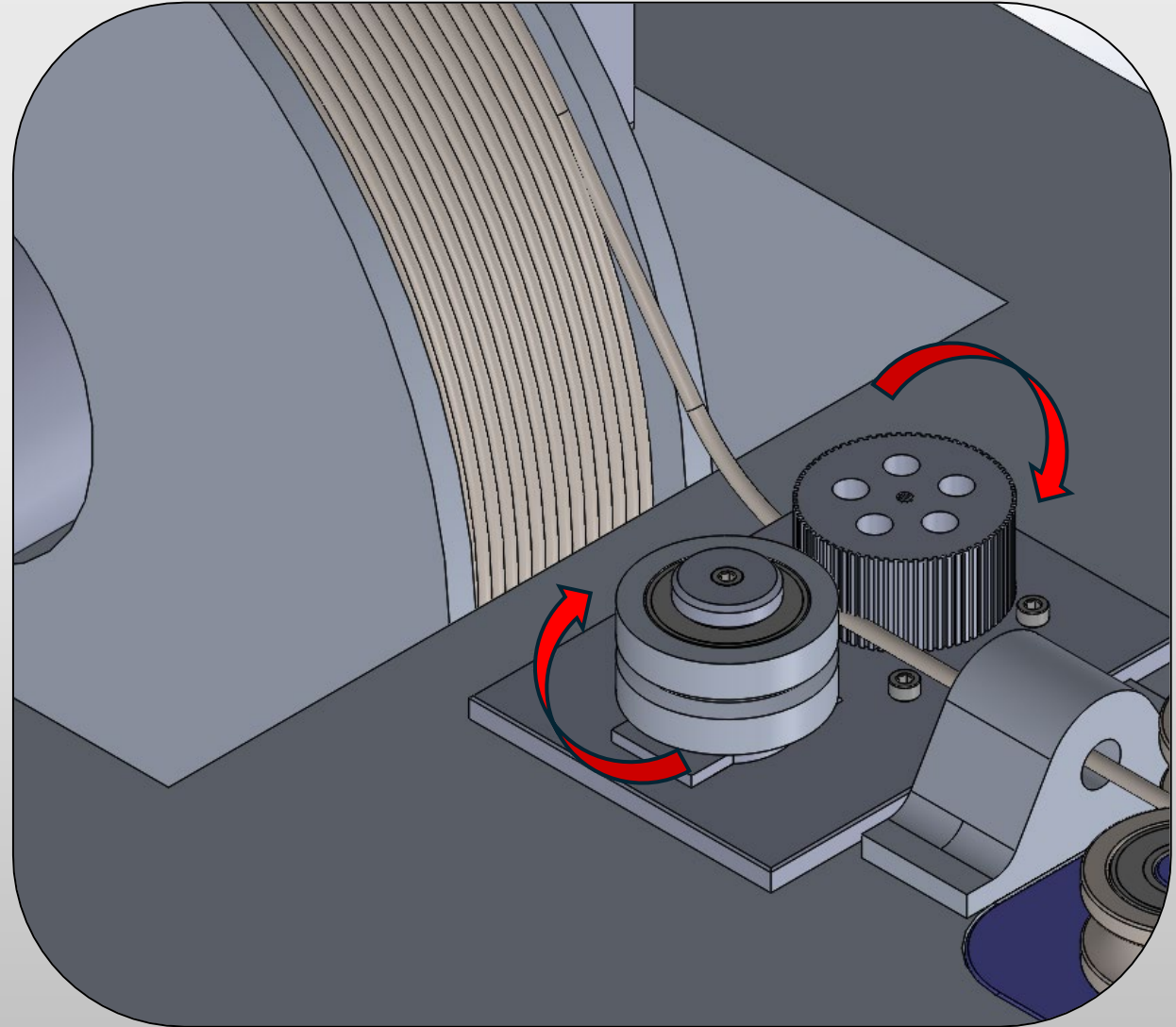

Systems and Concept Operations: Straightening

- 5 Rollers are positioned in a way to remove any additional bends right after the feeding stage

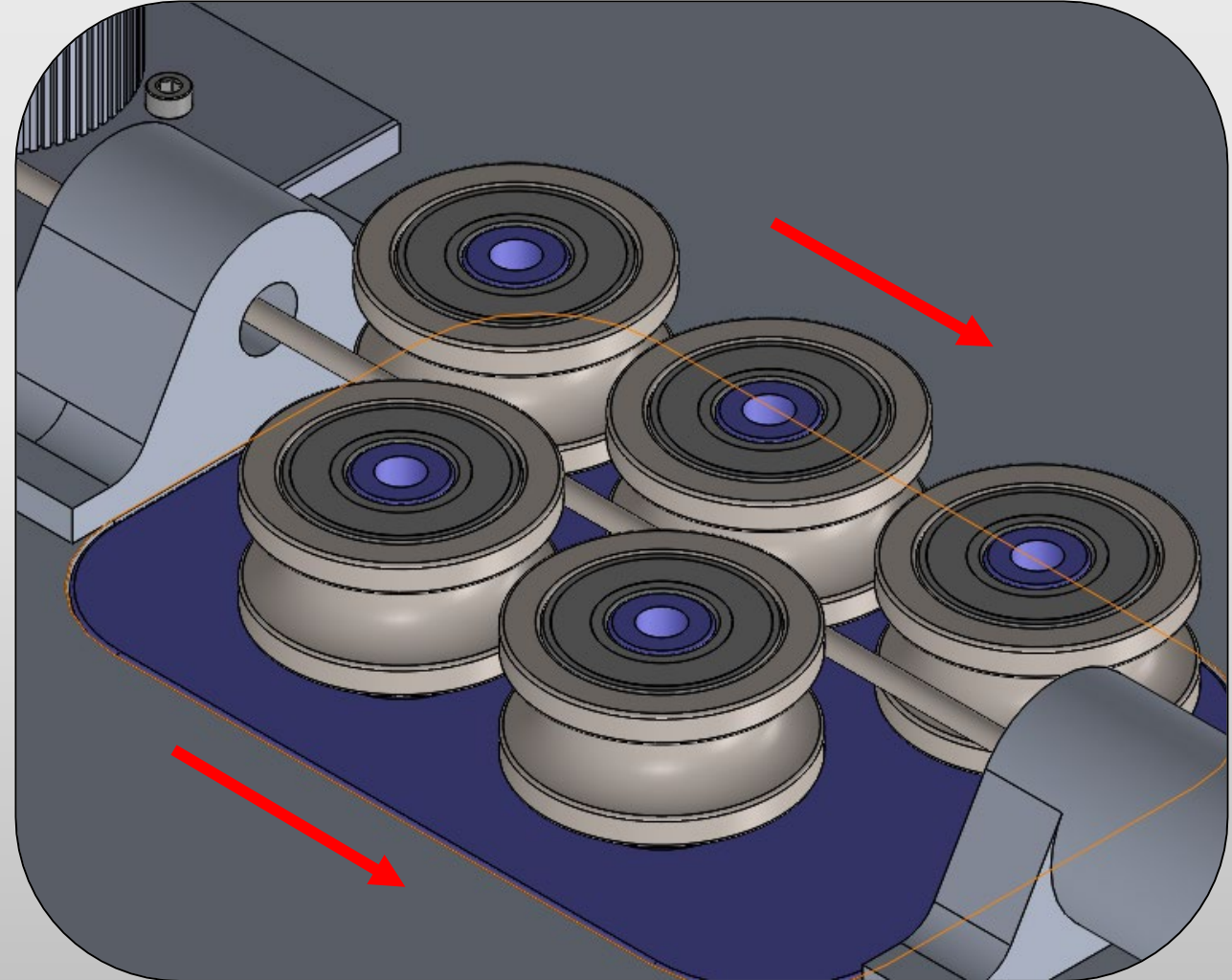

Systems and Concept Operations: Bending

- Bending will be administered by the NEMA 23 stepper motor, with it's own included gear box to produce more torque than a traditional NEMA 23 motor.

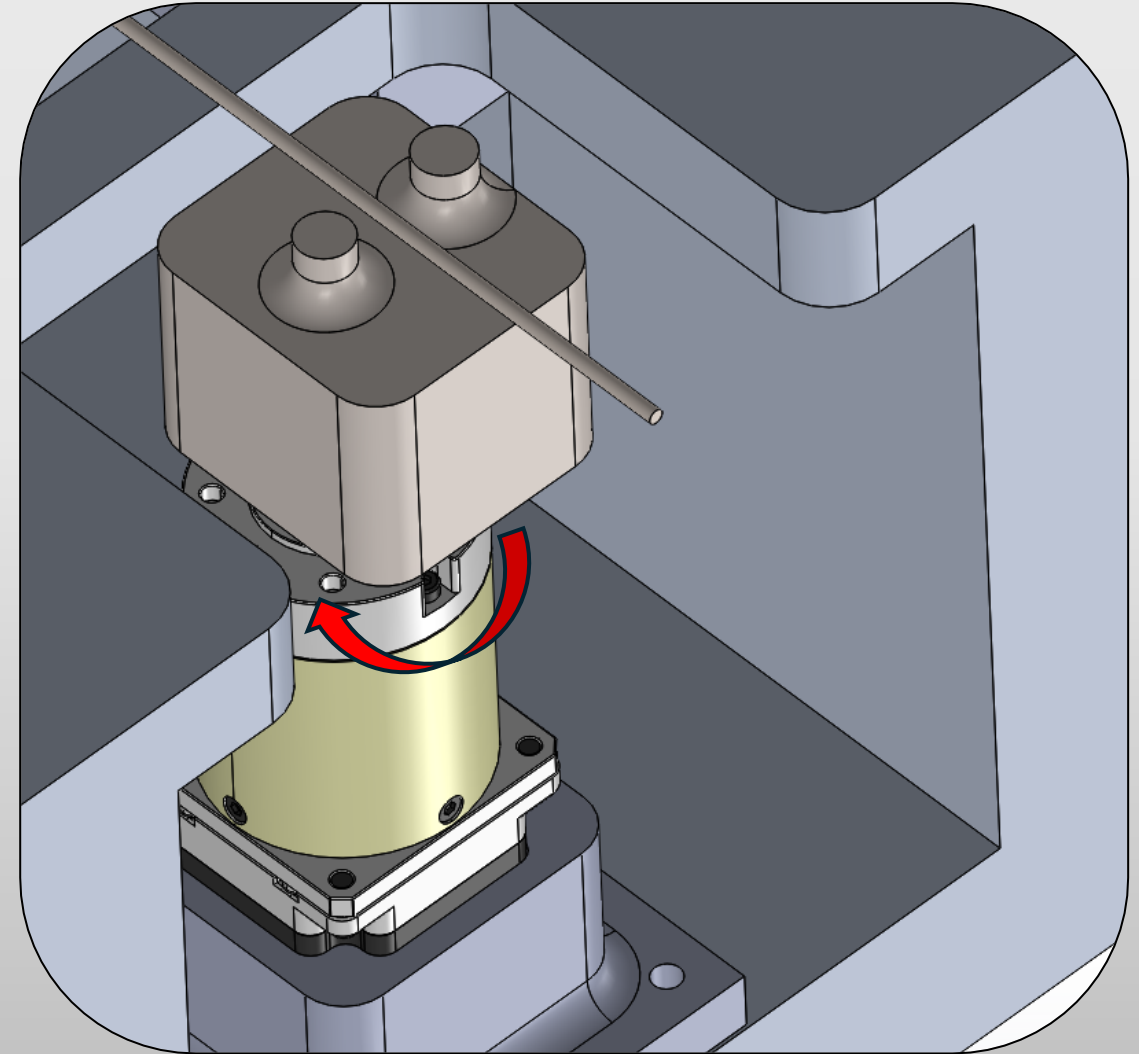

Systems and Concept Operations: Cutting

- Two titanium blades will come to the center of the wire bending machine and shear of any additional material
- This mechanism is driven by a lead screw

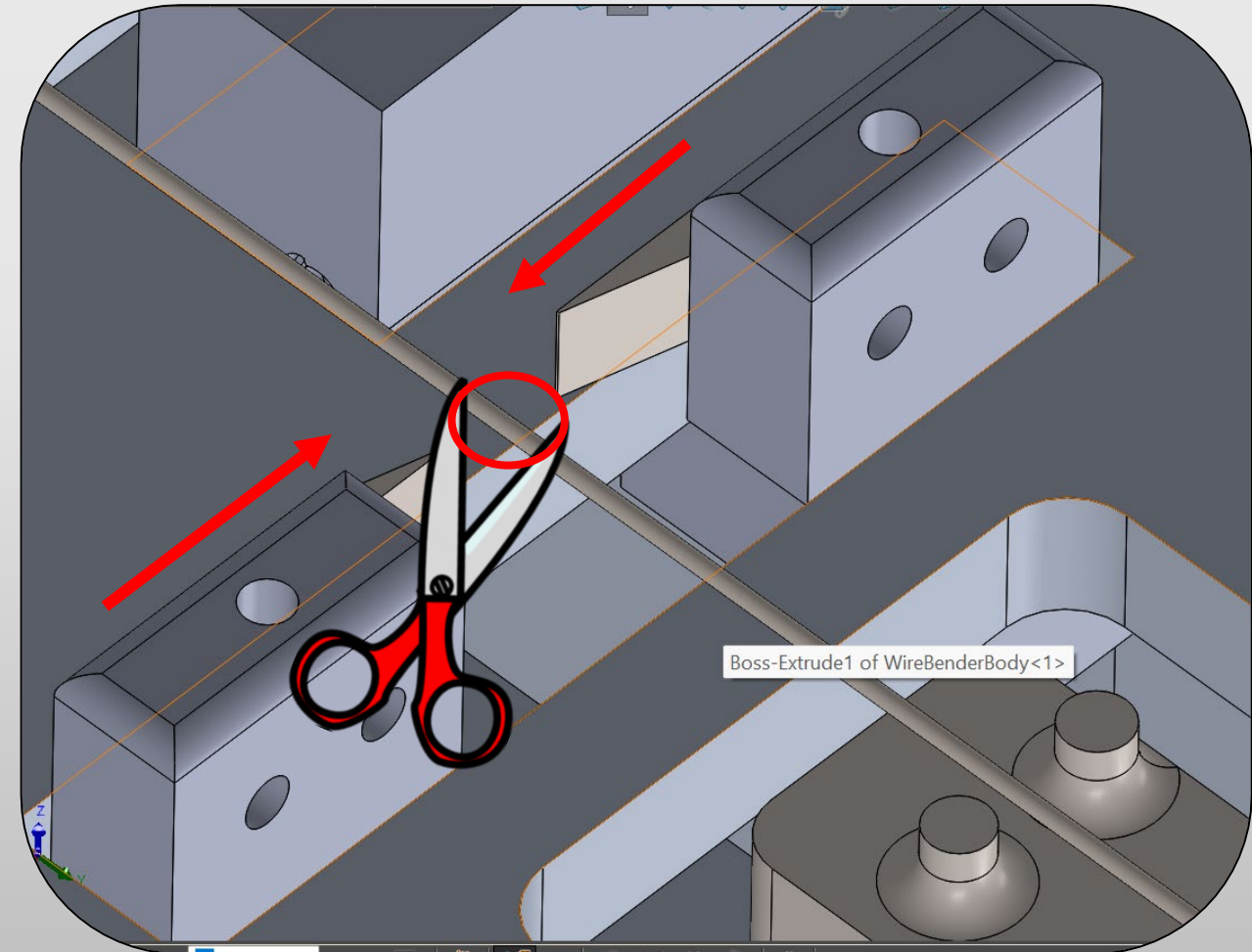

Systems and Concept Operations: Fastening

- The fastening process is carried out using a clamshell-style die, which houses two produced modules and enables controlled wire wrapping to secure the assembly.



Systems and Concept Operations:

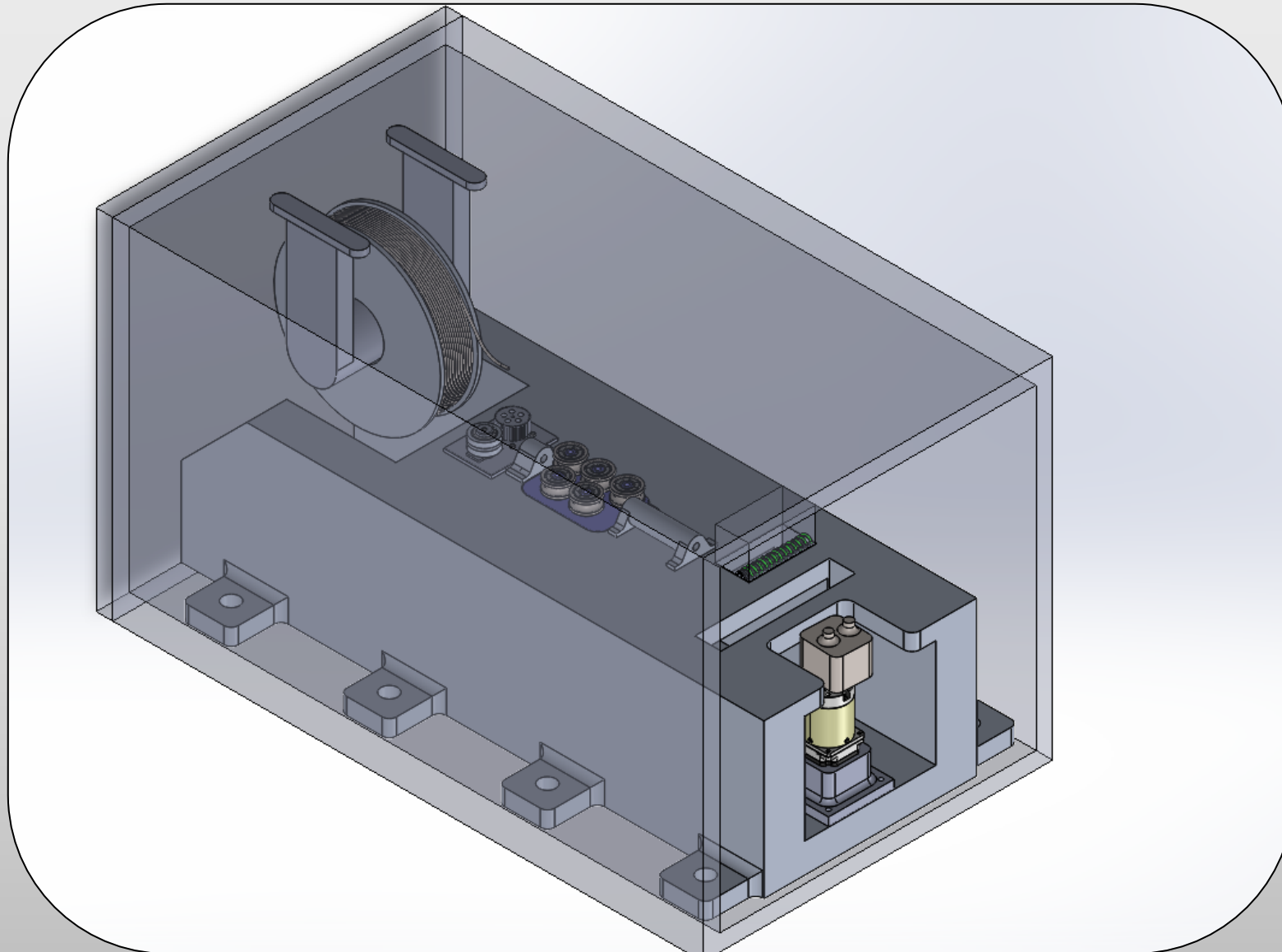

Systems and Concept Operations

- Our goal is to streamline command transmission from Earth so that operating the Wire bender is as intuitive as launching slicer software, with the machine autonomously executing the task.
- Hopefully, one day

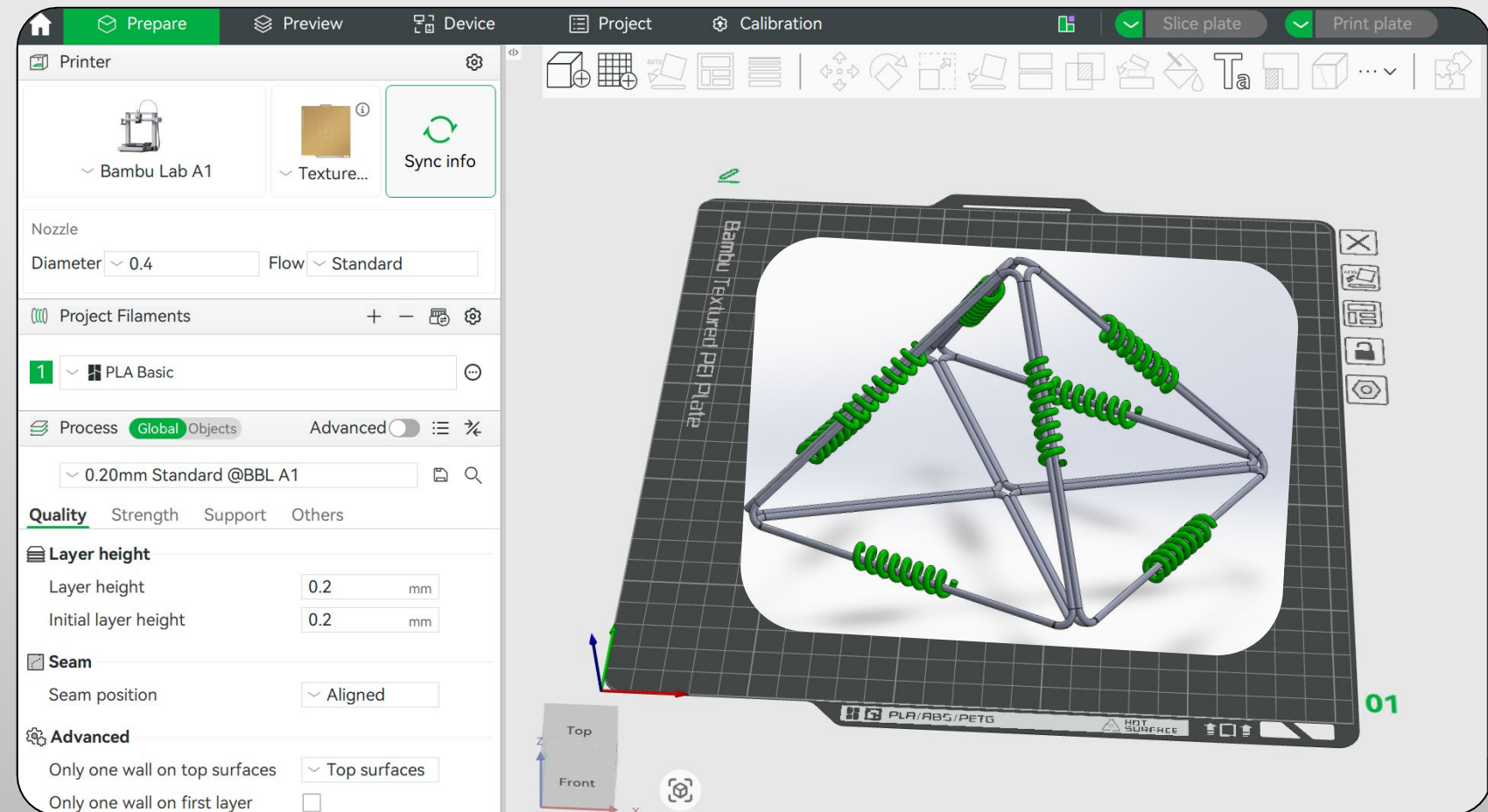

Engineering Design and Analysis: Bending Head

- Factor of Safety of 12
- Maximum stress is significantly below the yield stress

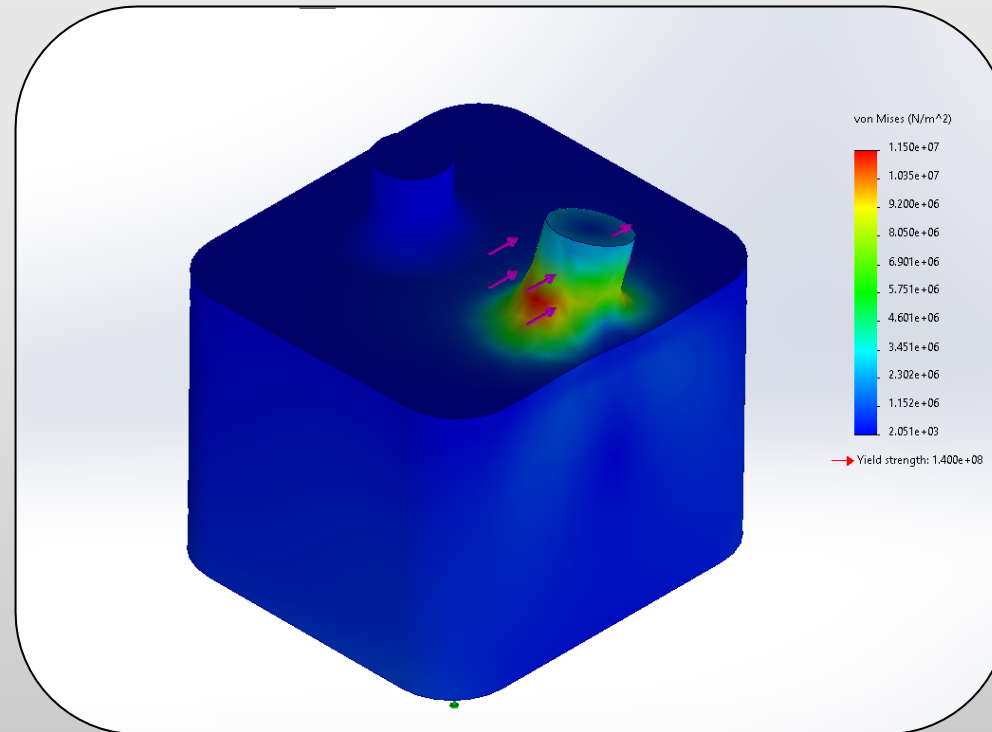

Engineering Design and Analysis: Requirements Adherence

- Under 300 Watts ✓
- Our design has a sustained Wattage around 253 Watts
- This can go higher depending on wire diameter size
- Design also fits within 15.75" x 15.75" x 35.45" ✓

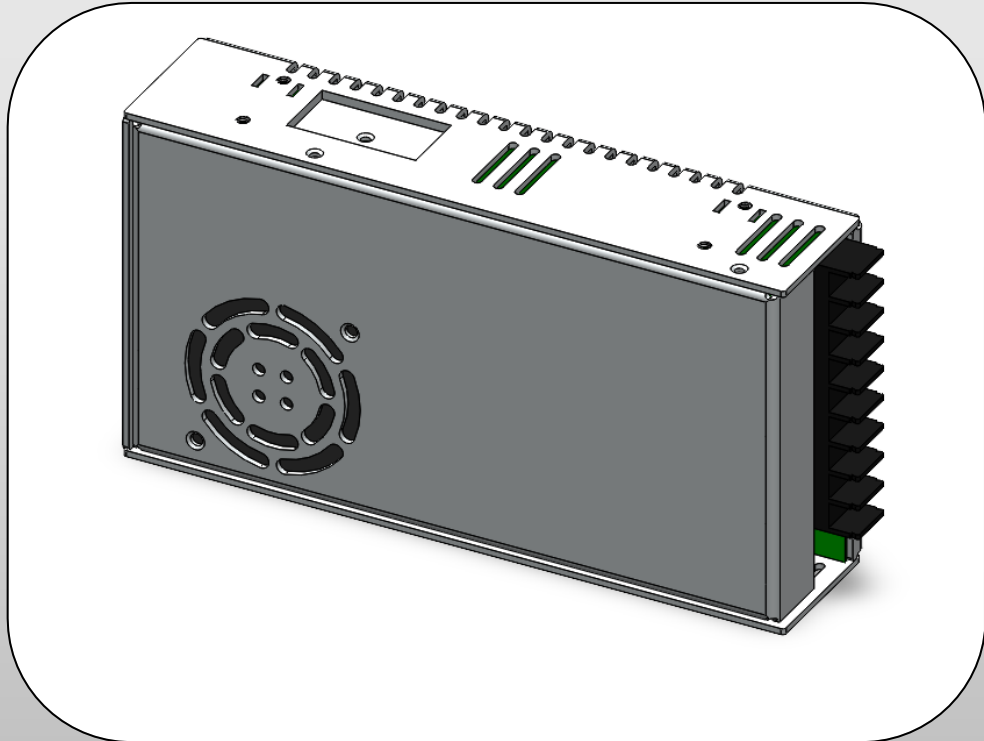

Engineering Design and Analysis: Bill of Materials

- Bill of Materials does not include nuts & bolts
- We estimate that a system like this will likely cost around **\$3,000-\$5,000**

Bill of Materials		
Part Description	Material	Quantity
Bending Head Body	Aluminum	1
Feed Roller	Titanium	1
Idler Roller	Titanium	1
Feed Roller Plate	Aluminum	1
316 Stainless Steel Wire Spool	316 Stainless Steel	1
Wire Spool Holder	Aluminum	1
Channel Guide	Aluminum	2
Straightener Rollers with Base	316 Stainless Steel	1
Bending Head	Titanium	1
Wire Spool Mount	Aluminum	1
Electrical Power Supply	Copper/Aluminum	1
Stepper Motor Driver	Copper/Aluminum	2
NEMA 17 Stepper Motor	Steel/Copper	4
NEMA 23 Stepper Motor	Steel/Copper	1
Arduino	Steel/Copper	1
Fastening Die	Steel	1

Engineering Design Development

- Originally, we had our spool in a horizontal mounting point, which posed some slight problems
- Fastening was not included yet

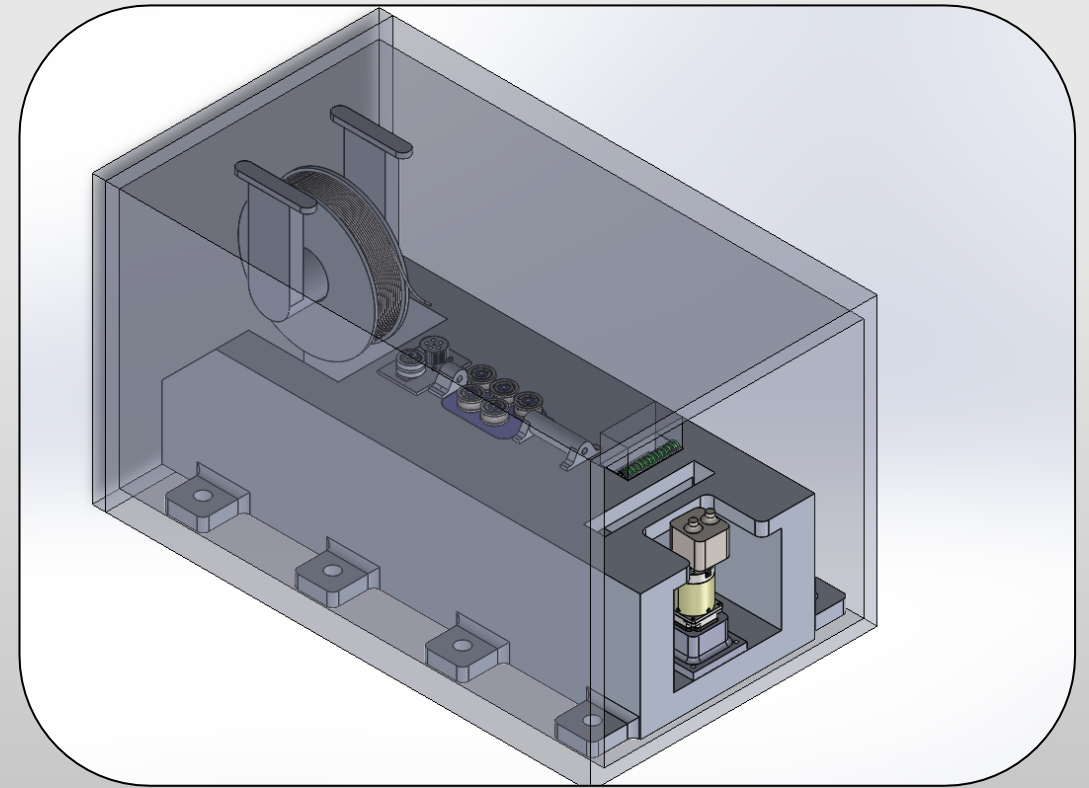
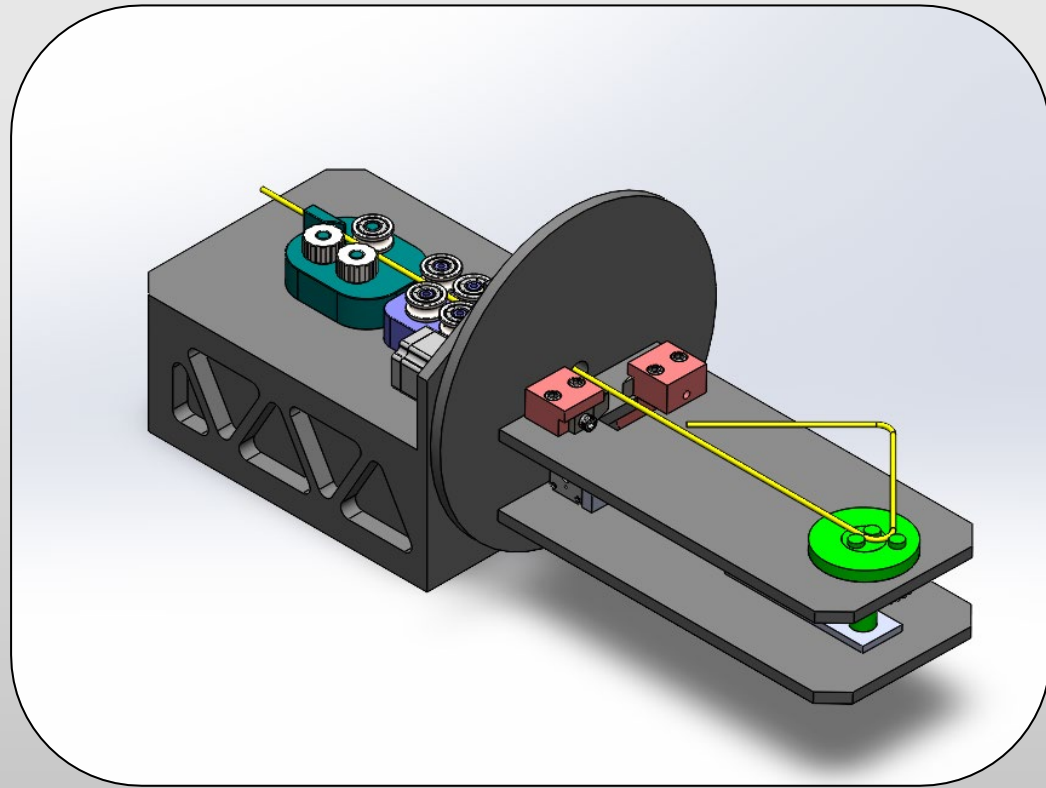

Trade Studies: Scoring

Criteria Definitions		Scoring Method	
size	How much space the design takes up in the bender and how easily it fits with other parts.	Score	Meaning
mass	The total mass added by the design, including any mounts or supports.	1	Poor / Unacceptable
power consumption	How much electrical power the design uses during operation.		
thermal	How well the design handles temperature changes without losing performance or causing	2	Acceptable
reliability	How consistently the design works over time with little risk of failure or maintenance.		
accuracy	How well the design meets its performance goal (example: feed rate, bend angle, or cut).	3	Optimal
complexity	How difficult the design is to build, assemble, or maintain — simpler designs are better.		

- Applied a weighted decision matrix to evaluate design alternatives
- Scored each concept on a 1–3 scale
- Selected concept based on the highest overall score

Trade Studies: Feeding

- **3 Roller Feed System (Winner)**
 - **Pros**
 - High accuracy in feed rate
 - Less slip, better control
 - **Cons**
 - More components
 - Increased mass

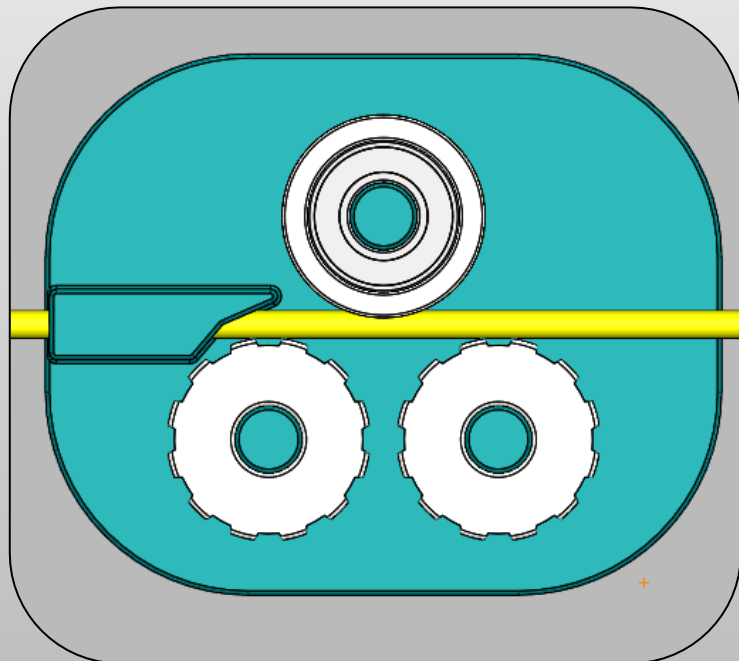

Operation: Feed				
Criteria	Weight	3 Roller Feed System	Mig Welder Feed System	2 Roller Feed System
Size	10%	2	1	3
Mass	10%	2	1	3
Power Consumption	20%	2	2	2
Thermal Resistance	10%	3	2	2
Reliability	20%	3	3	2
Accuracy	25%	3	3	1
Complexity	5%	2	1	3
Total Score	100%	2.55	2.20	2.00

Trade Studies: Straightening

- **5 Linear Rollers (Winner)**
 - **Pros**
 - High accuracy and Repeatability
 - Adjustable Offset
 - **Cons**
 - More components
 - Larger assembly footprint | larger mass

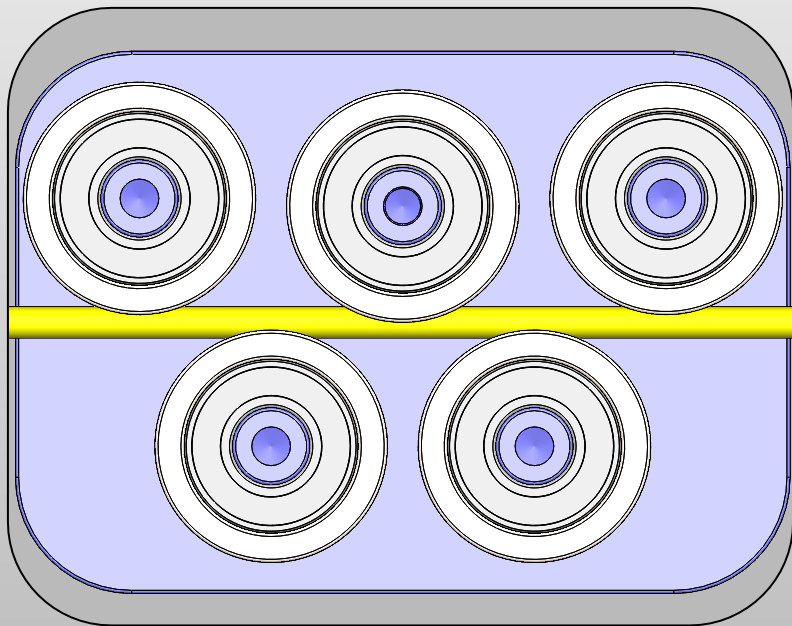

Operation: Straightening				
Criteria	Weight	Drawing Die	Multi Axis Series Rollers	5 linear Rollers
Size	10%	3	1	2
Mass	10%	3	2	2
Power Consumption	15%	1	2	2
Thermal Resistance	10%	2	2	2
Reliability	20%	2	3	3
Accuracy	25%	1	3	3
Complexity	10%	3	1	2
Total Score	100%	1.90	1.90	2.45

Trade Studies: Fastening

- **Wire Wrap Die (Winner)**
 - **Pros**
 - Strongest joining process
 - Highest repeatability
 - **Cons**
 - Complex design
 - Increased mass

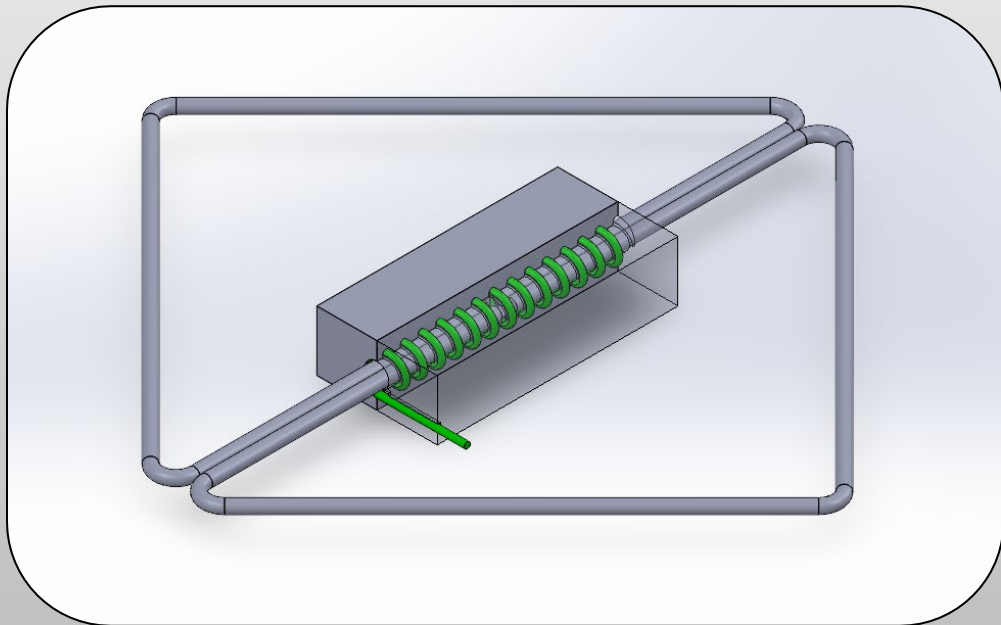

Operation: Fastening				
Criteria	Weight	Wire Wrap Die	Knot Forming	Integrated Staple
Size	10%	2	1	1
Mass	15%	2	1	1
Power Consumption	20%	2	1	1
Thermal Resistance	15%	3	2	2
Reliability	15%	2	2	2
Accuracy	20%	3	1	2
Complexity	5%	2	1	1
Total Score	100%	2.35	1.30	1.50

Trade Studies: Materials

- **316 Stainless Steel | 4 AWG (0.204")**
(Winner)

- **Pros**

- High corrosion & thermal resistance
- Ductility for bending operations

- **Cons**

- Higher mass than 304 SS
- Larger power consumption



Feed Material				
Criteria	Weight	304 SS	316 SS	410 SS
Size	N/A	N/A	N/A	N/A
Mass	20%	3	2	1
Power Consumption	25%	3	2	1
Thermal Resistance	15%	2	3	1
Reliability	20%	2	3	1
Accuracy	20%	2	3	1
Complexity	N/A	N/A	N/A	N/A
Total Score	100%	2.25	2.75	1.00

Prototype

- The fastening objective was not achieved due to complexity of machining
- Wire was cut manually using shear cutters
- Bench power supply and Arduino were used to send commands

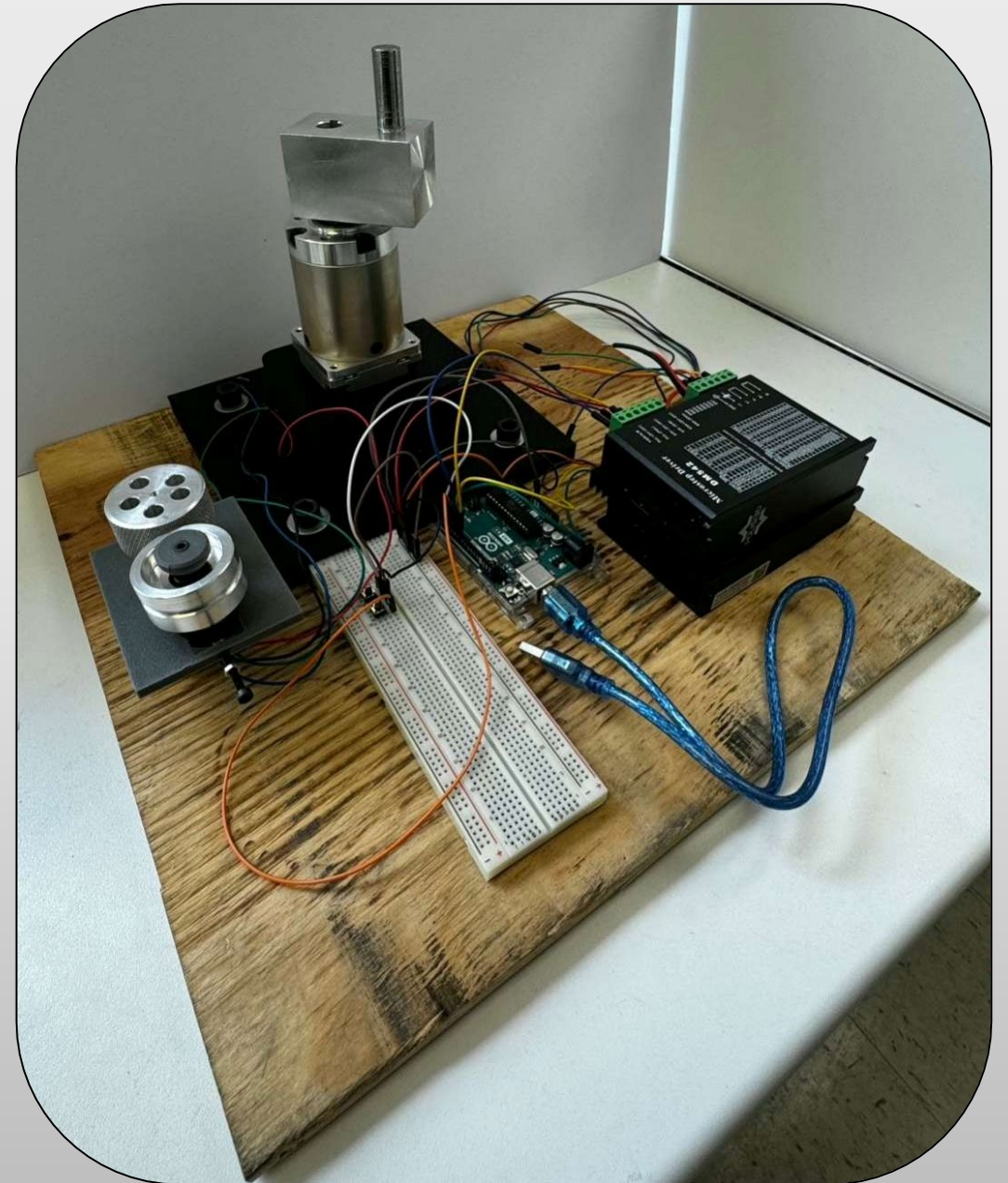
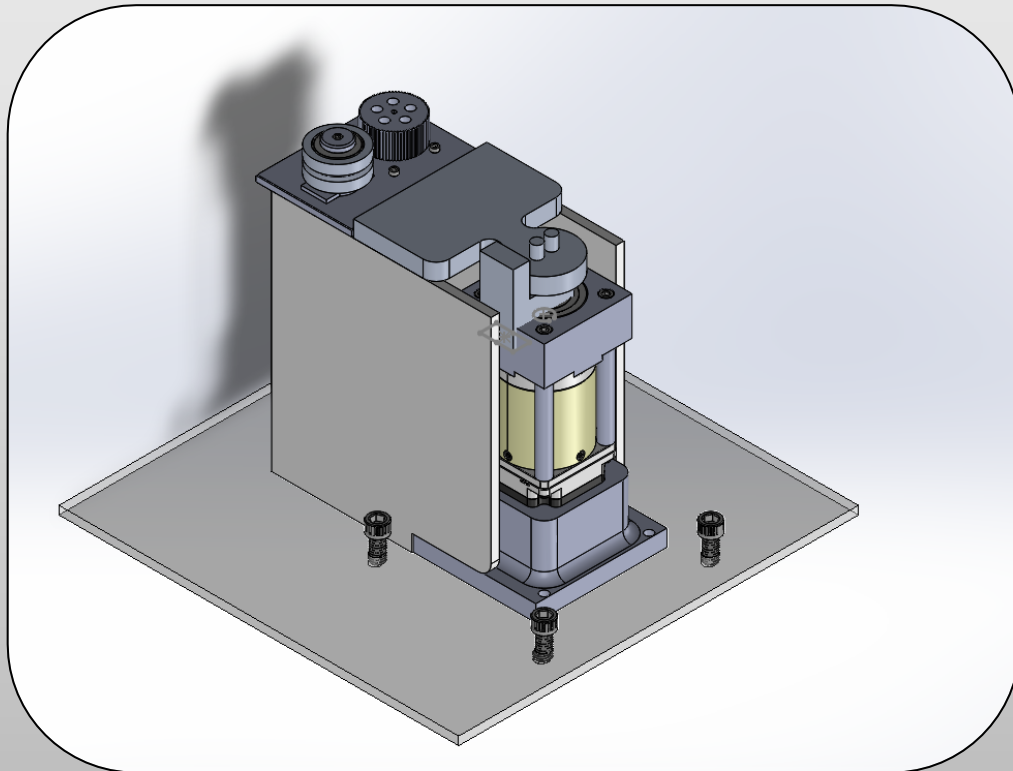

Risk Mitigations

- **Aluminum guide acts as a safeguard in case excessive wire bending prevents smooth entry into the straightener**
- **Debrise from shear cutting**
- **Locker Rotating during wire bending operation**

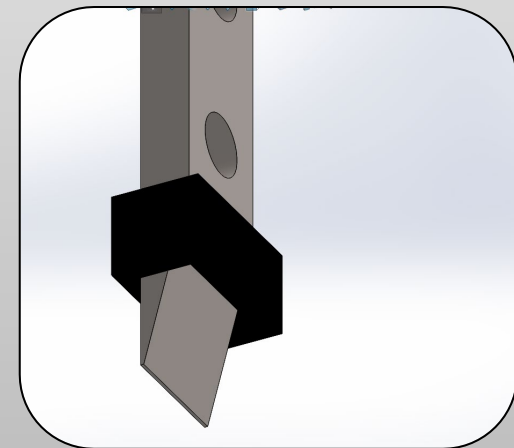
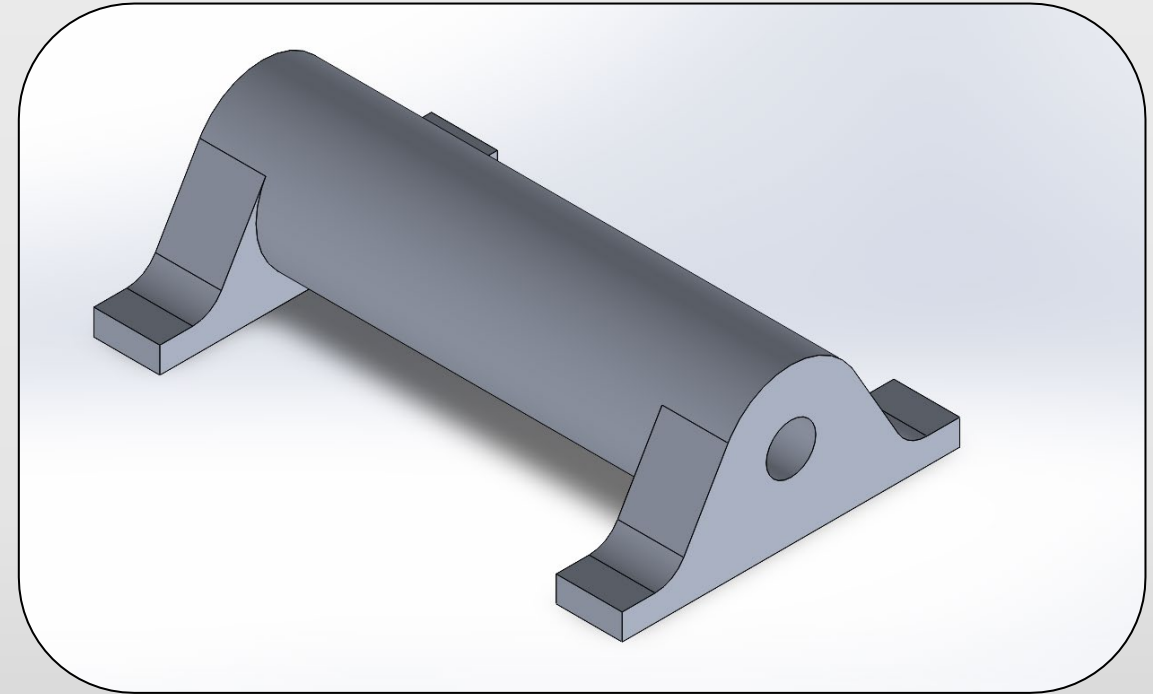

Lesson's Learned and Conclusion: Challenges

- **Self-intersecting geometry limits viable structures**
- **The fastening system must be housed in an independent locker due to the self-intersecting geometry**
- **With self-intersection, the bending head would need retraction ability to allow for clearance**

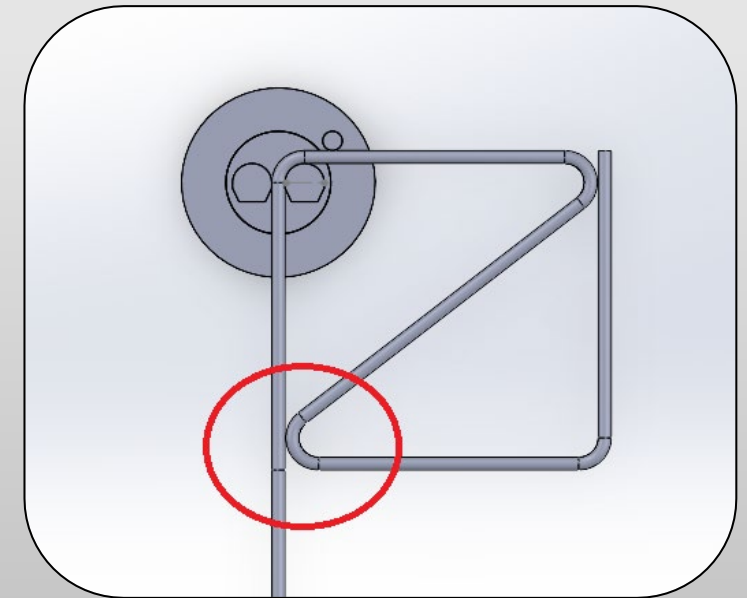
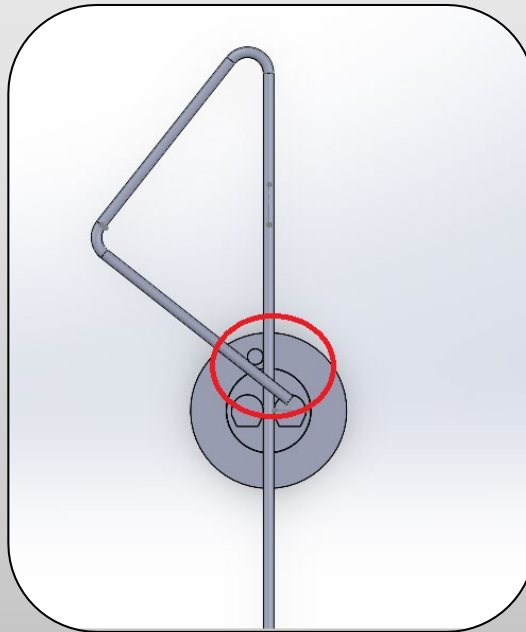
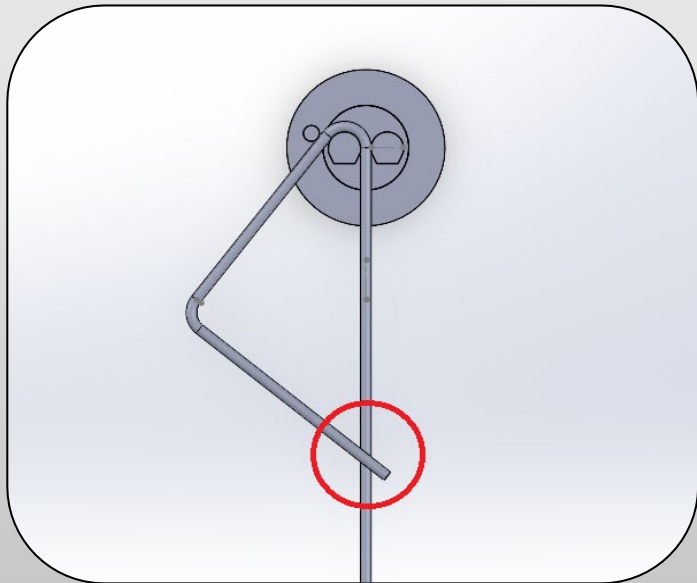

Note: Self-Intersection Points

Lesson's Learned and Conclusion: Reflection

- Innovative ideas that our team had but did not pursue further: Heat tubes, Pre-tensioned members, Tensegrity Structure
- Using Invar Alloy for fastening
- We should have pursued a different design

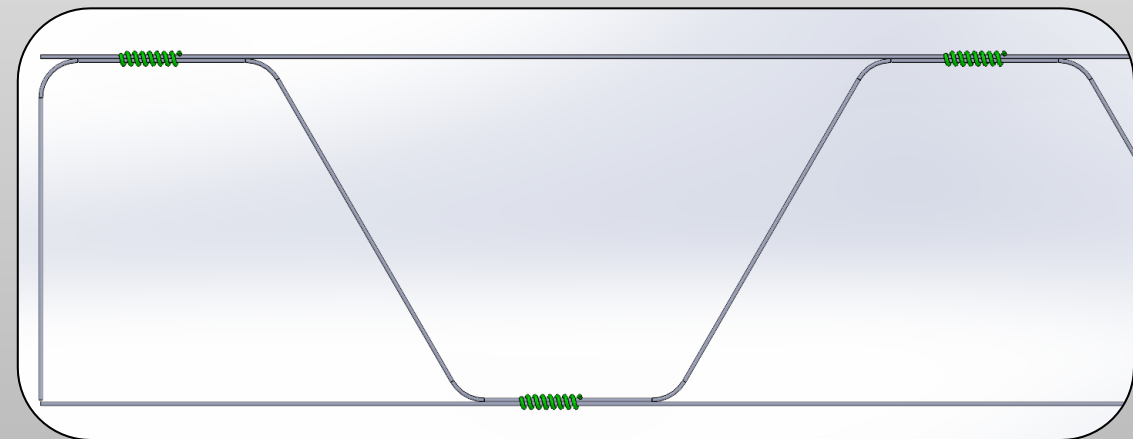
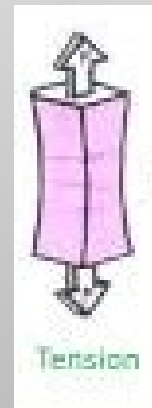

Lesson's Learned and Conclusion: Reflection



Lesson's Learned and Conclusion: Closing Statement

- **Additional time is required to address and resolve the self-intersecting geometry issue**
- **The fastening concept is promising, but it must be housed in a separate locker to work properly**
- **We had fun working on this project!**